

Concealing counterweight

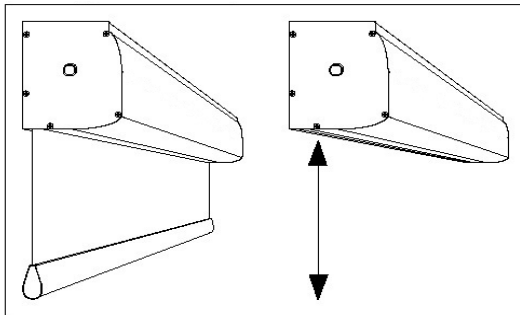

Cabinet dimensions

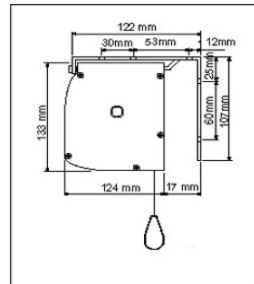

Wall Mounting

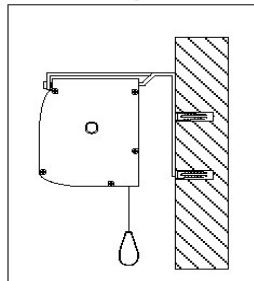

Ceiling Mounting

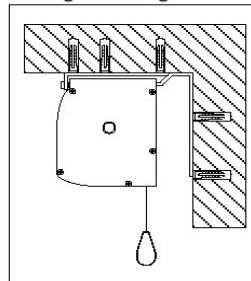

Motor characteristics

Power: 6 Nm
 Speed: 17 rpm
 Power supply: 230V / 50 Hz
 Consumption: 90 W
 Certification: IMQ

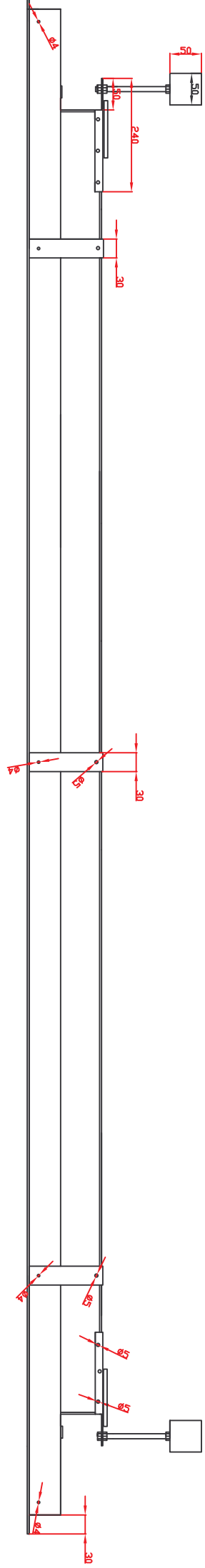

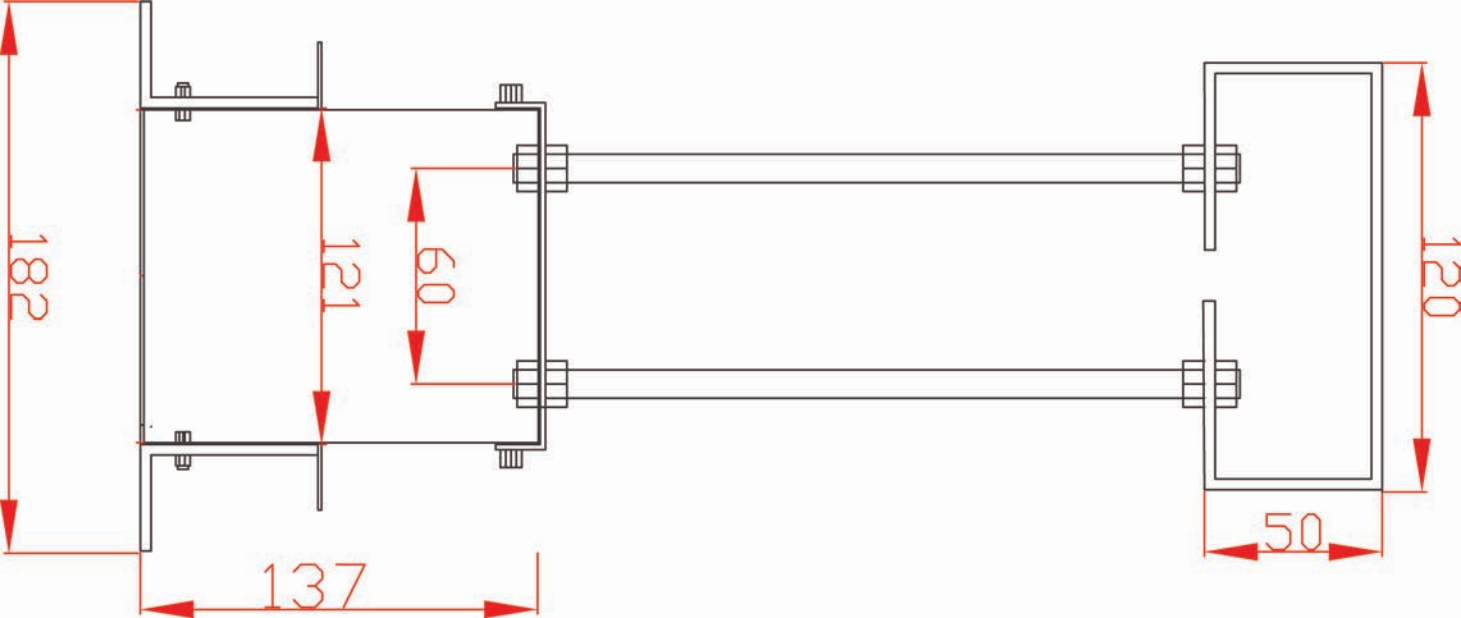

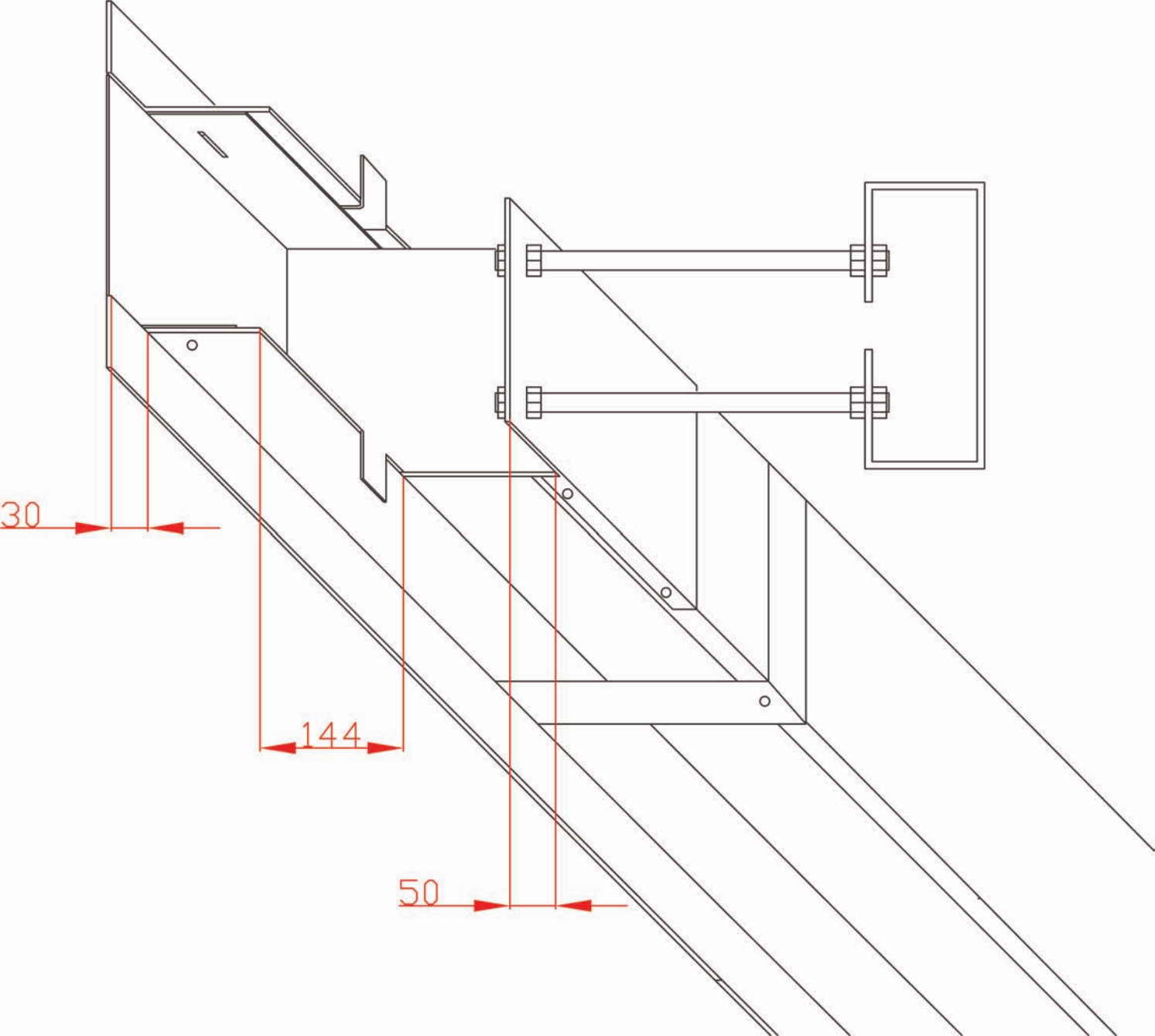

30

144

50